





At Pelican, we know protection from the outside in and from the inside out. As the inventors of the legendary Pelican Case, and the owners of the proven Hardigg Industry Cases, we continue to be the leader in built to protect solutions to equip for the mission. To some, we provide an essential way to protect your gear. To others, we provide a badge of honor. But to everyone, the iconic Pelican Case is a symbol of empowerment to enable the mission. Balancing our earned iconic status with our continued quest for innovation has always been the key to accomplishing the millions of missions — past, present, and future.

*James Curleigh*

James "JC" Curleigh // CEO, Pelican Products, Inc.



We engineer our cases to endure the toughest conditions. Whether they're dropped from the sky, submerged in the sea, or exposed to severe impacts, you can rest assured that your gear is always safe and sound. Leveraging industry-leading expertise and state-of-the-art technology, our world-class engineers create the most protective technical cases for the most critical missions — cases that feature innovative and customized protection on the inside and unmatched durability on the outside.

# UNRIVALLED PROTECTION



1976

It started with a specific mission in 1976: engineer fail-proof flashlights and cases to protect scuba divers. Guided by their innovative nature, Dave Parker and his wife, Arline, set out to build products better than any other on the market. Today, their pioneering past continues to fuel our innovative future.

# THE INNOVATION BEHIND INTEGRITY

When it comes to innovative protection, we define the standard. We're the ones who engineer what others simply can't. Utilizing proprietary processes, cutting-edge materials, and over 100 years of collective passion and expertise, there's nothing we can't protect — no matter how small, no matter how large, no matter how fragile. We're the most trusted name in mission-critical protection because our solutions are proven in practice and validated in real-world scenarios.



## EVERY OUNCE COUNTS:

Pelican-Hardigg™ Light Lift™ cases use a specifically formulated resin to make them up to 30% lighter than our standard heavy-duty roto cases.



2009

Hardigg has been a leader in airtight, watertight, and virtually indestructible rotomolded protective transport cases since its founding in 1954 by James S. Hardigg. In 2009, Pelican and Hardigg joined forces to become the premier name in protection.

## QUALITY & CONSISTENCY

Whether it's injection molded or rotomolded, you can expect the same product with the same quality from shipment to shipment every time you order it. No deviations. Guaranteed.

BUILT TO PROTECT



COMPUTER CONTROLLED  
MANUAL CHANGES NOT  
PERMITTED  
DATE: 11/14/14  
CASE CODE: 14  
DWG NO. 14



BUILT TO

**PROTECT**

TO EQUIP FOR

**THE MISSION**



# BUILT TO THE EXACT SPECIFICATIONS OF YOUR MISSION

It's a fact. Your equipment is integral to the success of your mission. That's why we take the time to thoroughly understand your equipment as well as the conditions and situations it will face. Our team of experienced engineers will partner with you to design, build, and test an innovative protection solution to your exact specifications — one that's guaranteed to keep your equipment protected so it's always ready to perform.

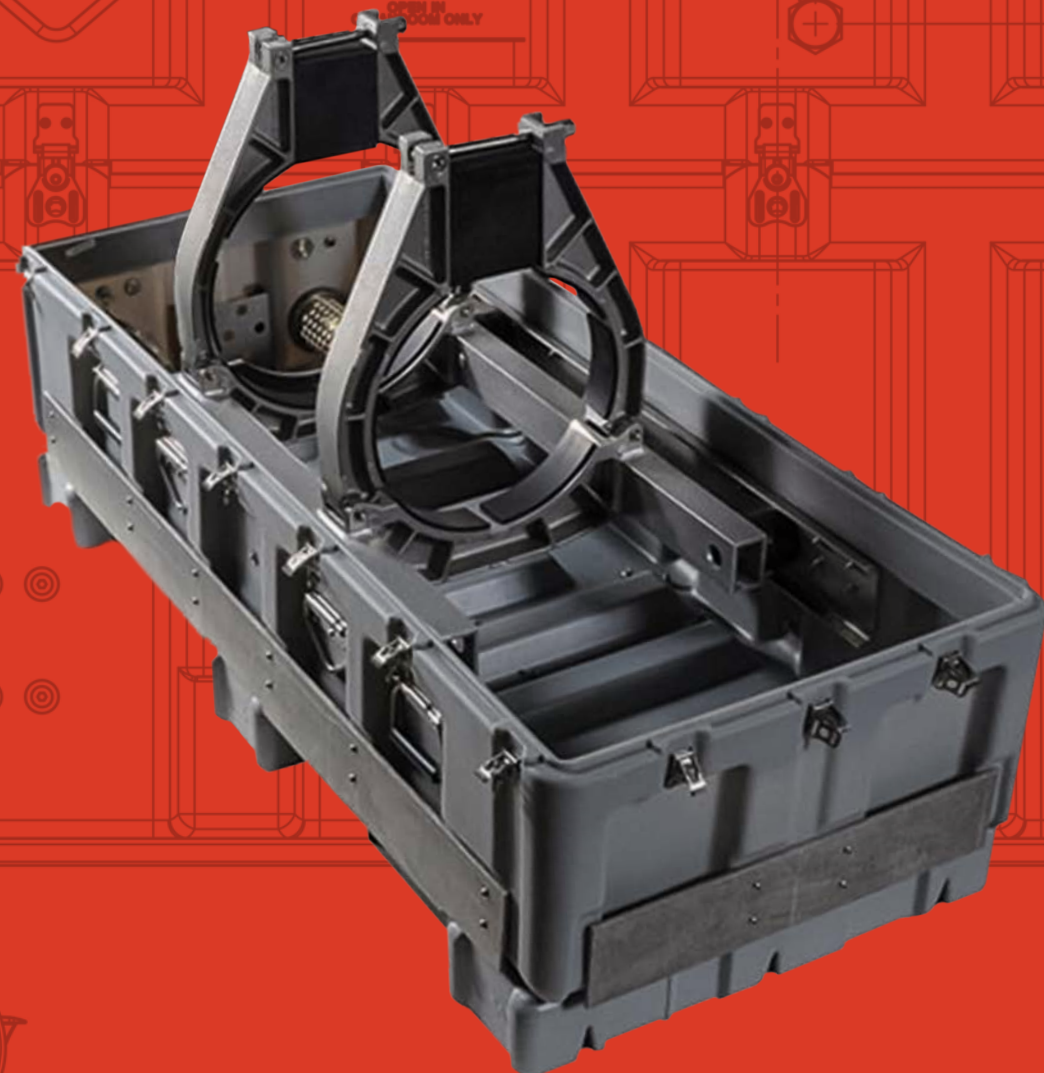

FRONT VIEW



**200+**  
PATENTS GRANTED  
FOR MATERIALS & DESIGN

**100K+**  
CUSTOM SOLUTIONS  
DESIGNED & ENGINEERED

**10M+**  
CASES PRODUCED

RIGHT SIDE VIEW



CAUTION PLATE	18375-0414	8	17	WASHER, SEALING, 5/16	P021-160-312-1	32	6	ADHESIVE, SIMSON	ISR 70-03A	A/R	E	5-27367	CHANGED NOTE
WASHER, O-RING SEAL	P021-0236-03	8	18	SHOCK MOUNT, C537-570RH	18375-0026	4	7	GASKET, ETHYLENE-PROPYLENE	P021-0811	13.0			
WSHR, S-BUP, SSP, 3/16	P021-0882-01	8	19	SCREW, HEX HEAD, SST	1/2-13 UNC-2A X .75 L	8	8	CONFIG CASTER PLATE #9	P21-1261	2			
RIVET	AD66H	8	20	WASHER, LOCK, SST	1/2"	8	9	BUTTON	P021-1075-1	4			
O-RING	2-088	8	21	WASHER, FLAT, SST	1/2"	8	10	COMPRESSION SPRING	P021-1076	4			
					18375-0402	1	11	SCREW, BUTTON HD, SOC, SST ISO 7380-A2	M6 X 1 X 25 MM L	16			

# WE SERVE TO PROTECT

Whatever needs protecting, there's a Pelican™ case ready for the mission. From made-to-stock injection molded cases to highly complex customized solutions, every Pelican™ case is engineered and tested to your specific needs.

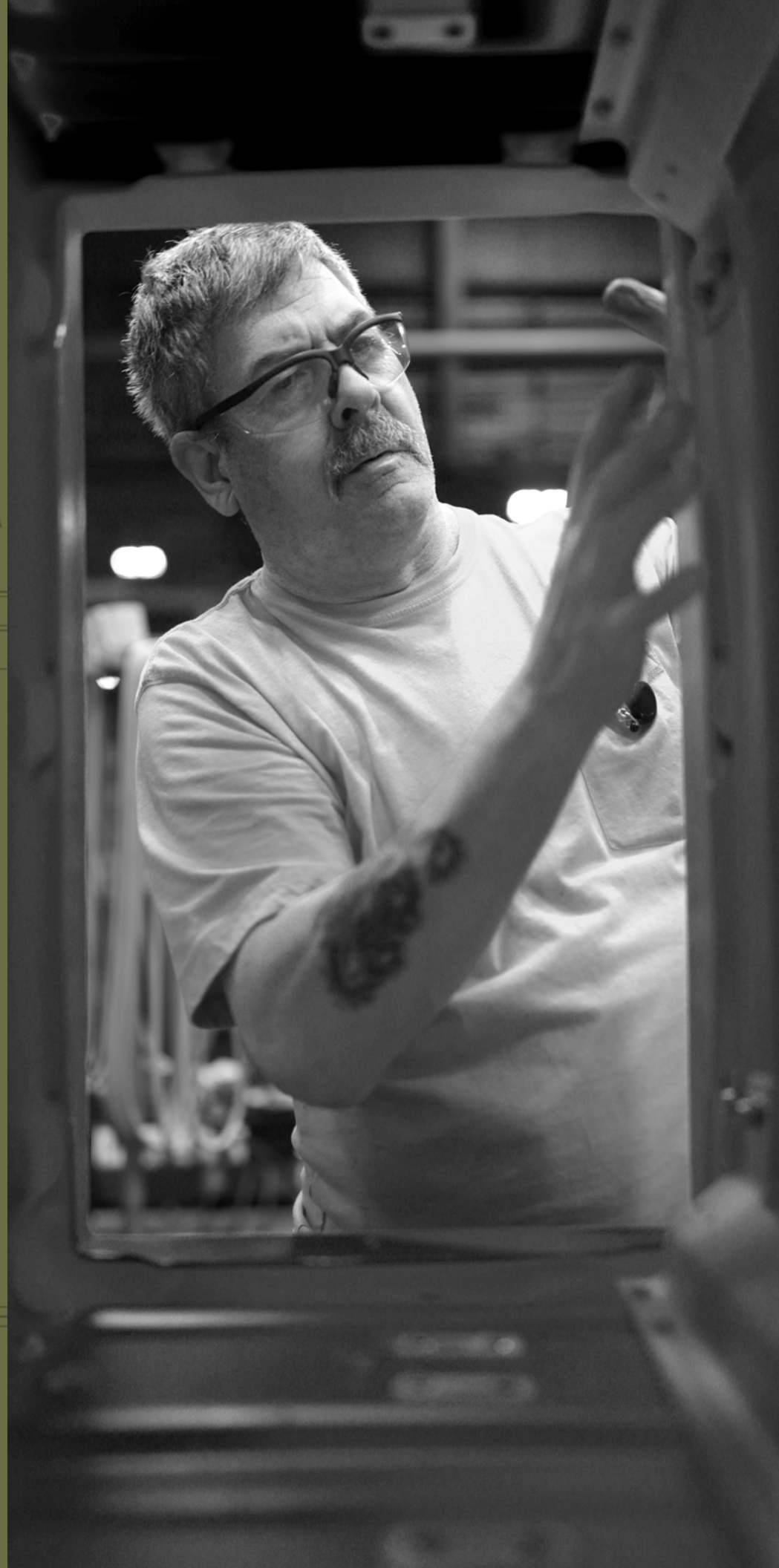

## EXTREME COMPLEXITY

Our highly customized cases are engineered to the exact specification of your needs and mission requirements. No matter how complex and fragile the equipment — or how complicated the mission — our world-class engineers use decades of experience and an unrivaled passion for engineering protective solutions to meet your needs.

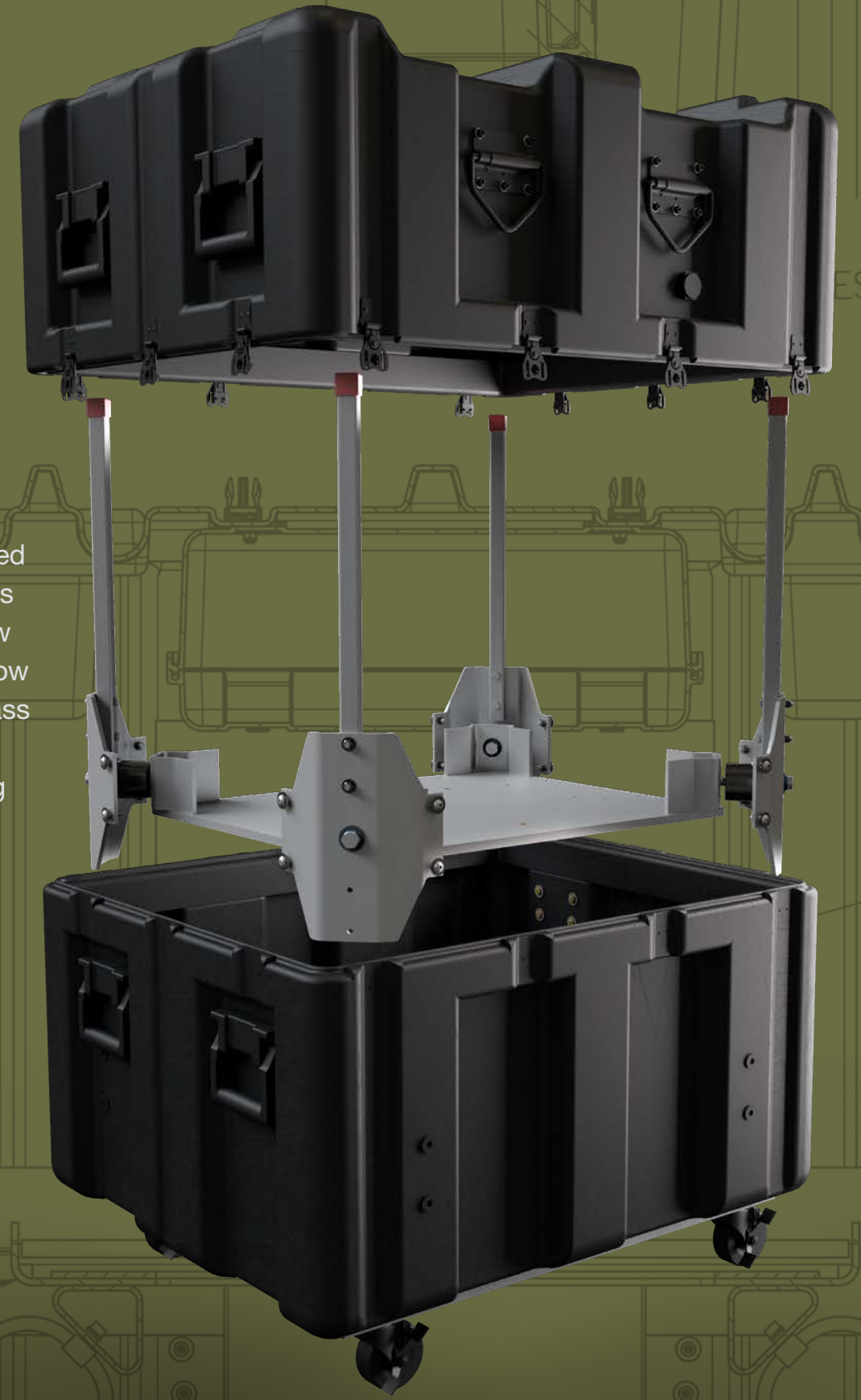

**MEDIUM COMPLEXITY**

Our rotomolded cases are made to order with configurable interior and exterior options like additional handles, forklift skids, and lightweight resins. They can also be outfitted with complex foam solutions for additional protection.

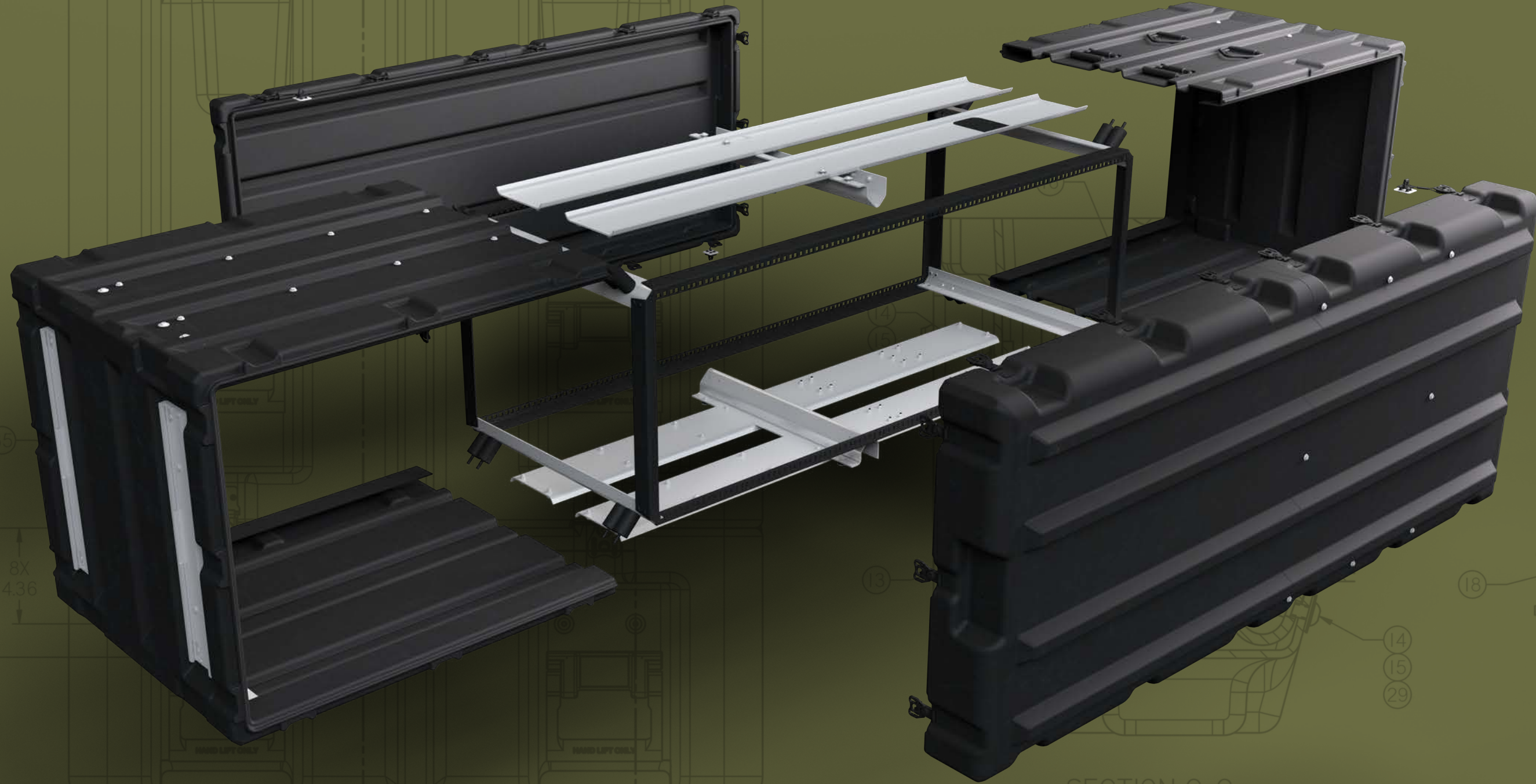

TOP VIEW

2X 6.62  
2X 13.25

SECTION C-C  
1:2

SECTION B-B  
ROTATED 90 DEGREES  
1:2



**LOW COMPLEXITY**

Our injection molded cases are made to stock and feature a standard interior with custom foam configurations for mission-ready protection.

SECTION A-A



Before our cases get used, they get abused — enduring the most rigorous quality testing in the industry to ensure unwavering protection under the most extreme conditions and situations. From impact and immersion testing to thermal, vibration, and environmental testing, they're guaranteed to keep your equipment safe while meeting all mandatory certifications for your mission.

# PROVEN TO PERFORM



**HAZMAT**



## TESTING

Our field-ready certifications include: MIL-STD-810, ATA Spec 300, ASTM, ANSI/NEMA FL 1 (flashlights), HAZMAT, REACH and RoHS compliant.

MADE IN

**THE U.S.A.**

PROVEN AROUND

**THE WORLD**



7. SEE TABLE I FOR SERIAL NUMBERS.

8. (DELETED).

22	WASHER, SEALING, 1/4	P021-1607-
23	NUT, HEX, PLASTIC INSERT, 18-8 SST	M6 X
24	BUTTON	P021-10
25	COMPRESSION SPRING	P021-10

**MISSION-CRITICAL ESSENTIALS**

Although the Pelican name is synonymous with protective cases, we also offer a full array of high-quality and mission-ready gear such as coolers, handheld lights, remote-area lights, drinkware, and mobile accessories.

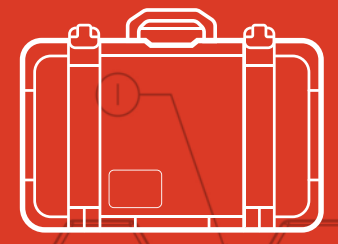

CASES

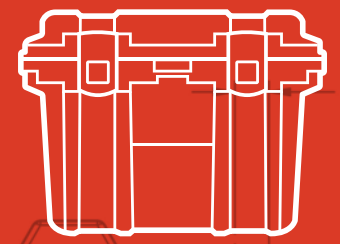

COOLERS

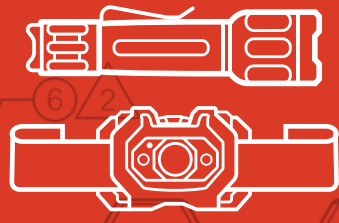

LIGHTS

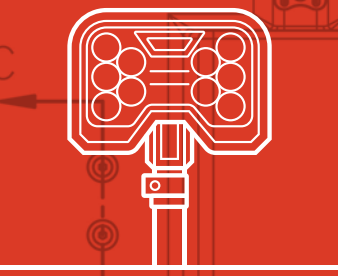

REMOTE-AREA LIGHTS



DRINKWARE

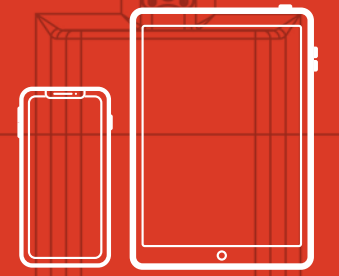

MOBILE

# OUR MISSION NEVER ENDS

As the global leader in protective cases since 1976, we take pride in who we are and what we've done. But truth be told, our focus isn't on the past but on the future. Simply put, our mission never ends. We're committed to engineering new products to better serve our customers with unrivaled protection. Because at Pelican, we believe there's nothing we can't solve, nothing we can't engineer, and nothing we can't protect.

11 GLOBAL OFFICES

4 MANUFACTURING FACILITIES

4 CUSTOM CASE CENTERS



2X 17.00

CONTRACT NO.

NEXT ASSY	FINAL	SCALE	1/4
TOLERANCE	UNLESS OTHERWISE SPECIFIED	XXX	IN
DR	DATE	ENGR	DATE
CHKD	DATE	LEVEL	DATE

**HARDIGG® INDUSTRIES, INC.**  
South Deerfield, Massachusetts  
01373 USA

COMPUTER CONTROLLED DOCUMENT  
MANUAL CHANGES NOT ALLOWED

37	WASHER, FLAT, SST	#10	2	24	NUT, HEX, LOCKING, SST, PLASTIC INSERT	1/4-20 UNC-2B	8	10	WIRE ROPE ISOLATOR	SBI2-290-04-B	4
38	NUT, HEX, LOCKING, SST, PLASTIC INSERT	#10-32 UNF	2	25	LONG SHOULDER SCREW	19980-710	3	11	DECK, MACHINED	19980-0702	1
				26	SHORT SHOULDER SCREW	19980-709	1	12	SCREW, FLAT HEAD, SOC, SST	1/4-20 UNC-2A X 1.25 L	16
								13	WASHER, SEALING, 5/16	P021-1607-312-1	24

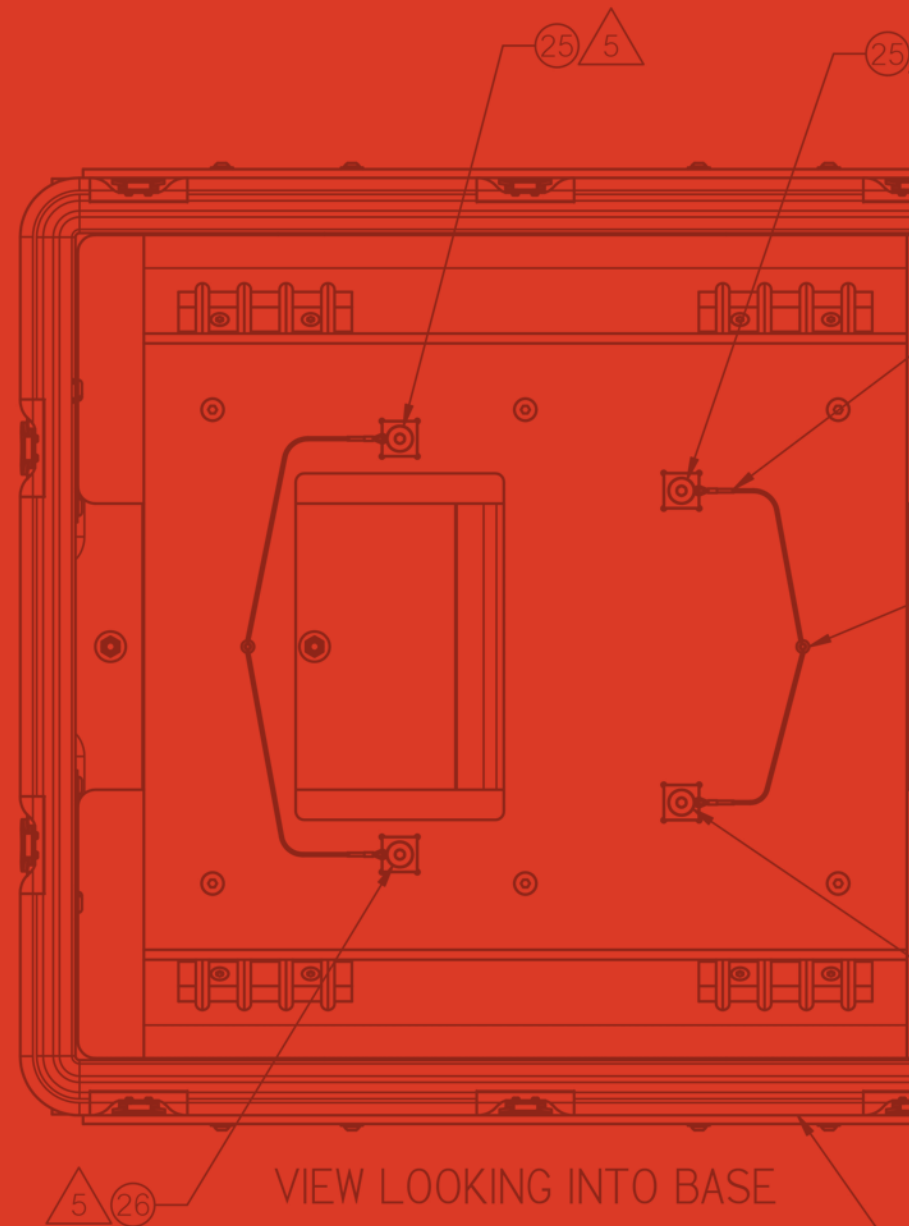
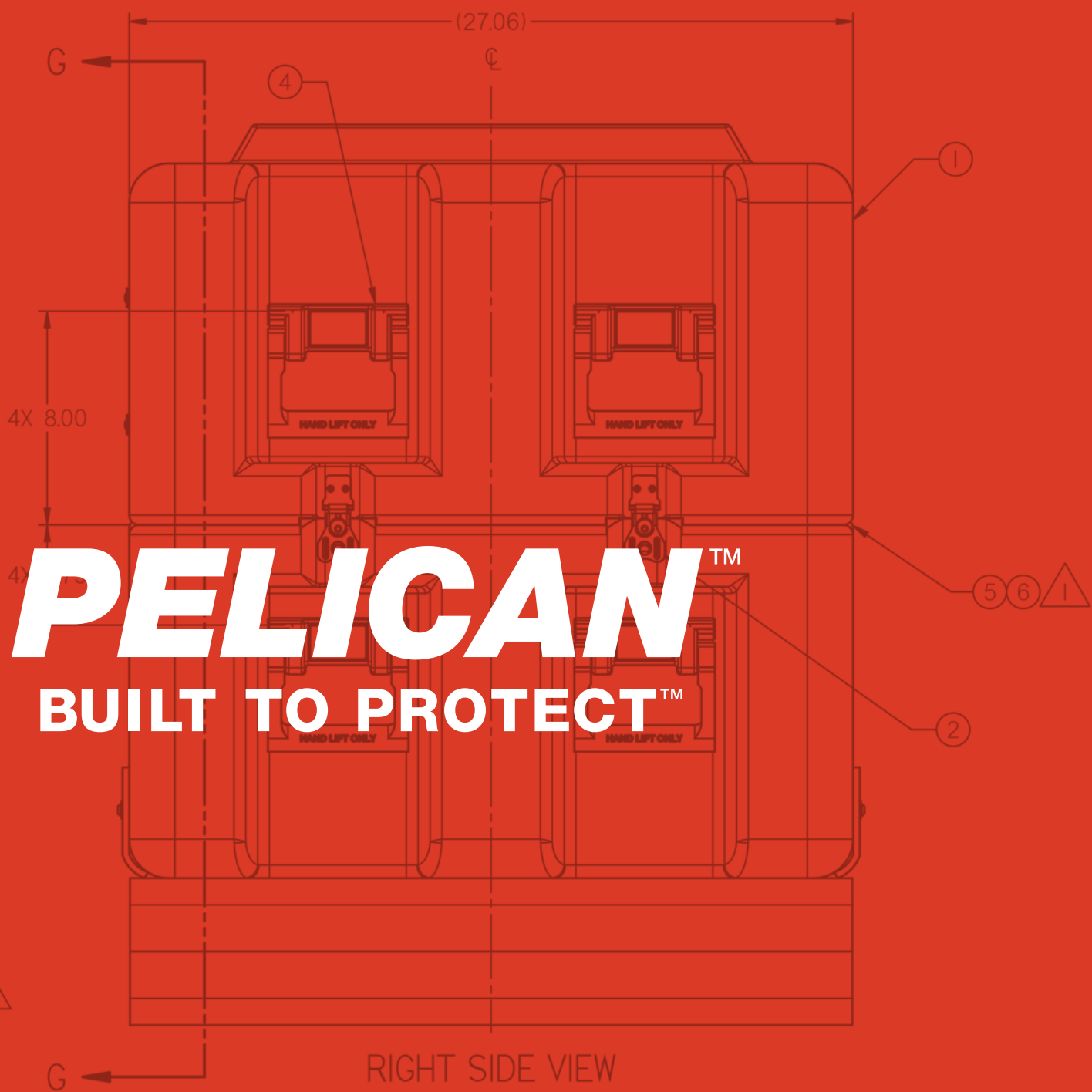
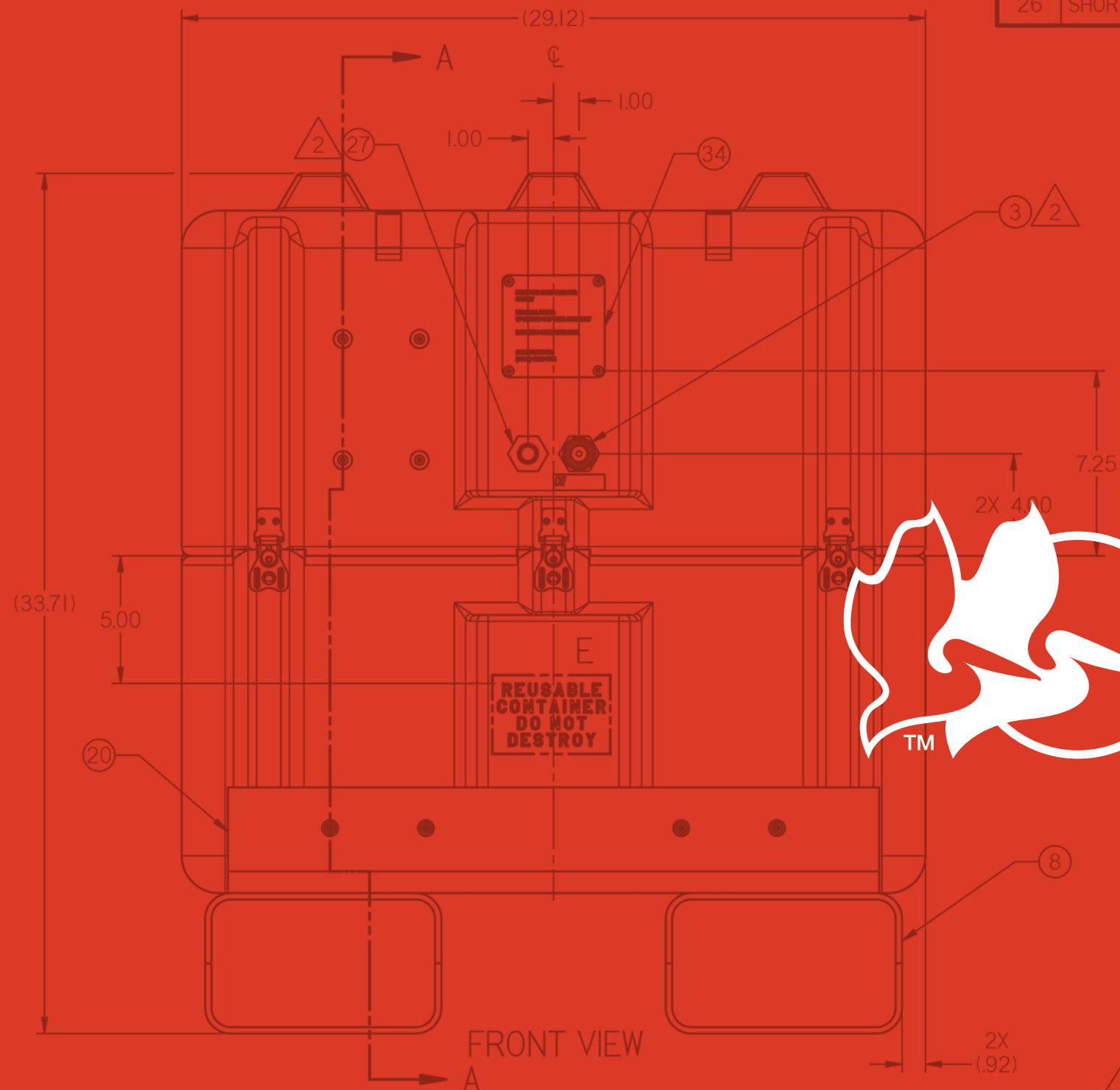

**PELICAN**<sup>TM</sup>  
**BUILT TO PROTECT**<sup>TM</sup>

REUSABLE  
CONTAINER  
DO NOT  
DESTROY

[pelican.com/business](http://pelican.com/business)

© 2024 Pelican Products, Inc. All trademarks are registered and/or unregistered trademarks of Pelican Products, its affiliates and/or subsidiaries.

CUST:  
UNIT:  
CONTRACT NO.

NEXT ASSY.	FINAL	SCALE	1/4
TOLERANCE	UNLESS OTHERWISE SPECIFIED	± .XX	± .XXX
DR.	DATE	ENGR.	DATE
CHKD.	DATE	APVD.	DATE

**HARDIGG**<sup>®</sup> **HARDIGG**<sup>®</sup>  
South Deerfield  
01373 USA  
CONTAINER