

TITLE: Pelican 1610 Transport Case Design Refinements

PRODUCTS AFFECTED: Pelican's 1610 Protector™ Cases

INTRODUCTION: The 1610 Transport Case design has been modified (**Excluding models manufactured in Germany**).

DETAILS: Revised measurements can be found at www.pelicanoe.com.

Design refinements:

Different Pick 'N' Pluck™ Foam Measurements

	Old Dimension	New Dimension
Convuluted foam	22.31" x 17.25"	22.4" x 17.38"
Pick 'N' Pluck	21.75" x 16.75"	22.12" x 17.12"

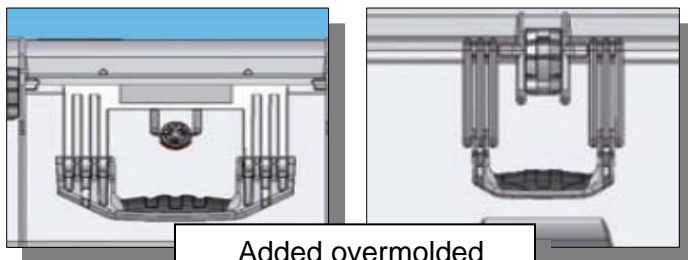

Added overmolded front and side handles

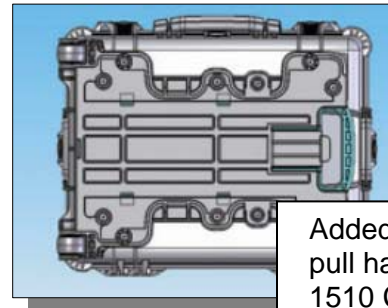

Added one-handed-action pull handle dolly (Similar to 1510 Carry On and 1560)

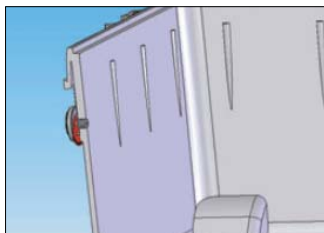

Inside wall thickness removed behind purge valve area to increase internal volume

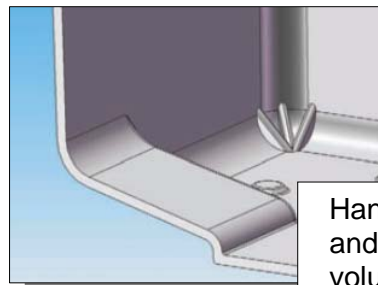

Handle recess area deepened and narrowed – less internal volume

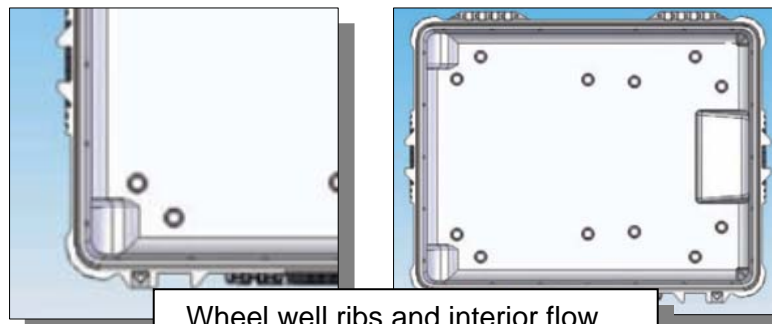

Wheel well ribs and interior flow channels removed to increase internal capacity

